

Bad weather can
ruin more than
just your day.

Spec Primex vents.
Engineered for the
harshest weather.



HVAC VENTING

Product Catalogue



HVAC Venting for Today's Building Envelope

At Primex, We Know Rain

A Building Envelope is Only as Strong as its Weakest Point

Operating around Canada's soggy West Coast has made us rainscreen experts by necessity. When the leaky condo crisis hit in the late 1990s we began working with building-science engineers and local HVAC contractors to set up a new standard.

Our goal? To better understand the relationship between something as simple as a roof vent and something as critical as the rainscreen.

After all, install the wrong roof vent or Wall Cap and that costly new rainscreen retrofit is doomed from the start.

So, this is the foundation we've built our product line on—maintaining the integrity of the building envelope.

Our simple, durable, and watertight HVAC solutions help keep buildings safe from leaks and water damage while ensuring proper, steady airflow.

This means our products are not only watertight and rainscreen compatible but are also capable of taking a beating from the elements.

Damaged, worn, or cracked vents and caps put the building envelope at as much risk as improper installation. Specially formulated polymer resins and carefully engineered molded designs have made our line of plastic products UV-proof, impact resistant, and warp resistant.

They never rust, won't dent when hit by an "errant" hockey puck, and retain their like-new colour for years and years.

In fact, at peak performance, we're proud to say our exterior plastic HVAC vents are designed to last for more than three decades.

Why Plastic is Stronger Than Metal

When it comes to choosing vents for HVAC systems, consider some of the long term differences between metal and plastic.

Metal options are often made with multiple leaky seams, can warp over time, dent easily, and if painted will chip or scratch.

Primex plastic HVAC venting options, by contrast, offer many advantages. Here are six of them.



1. WEATHER AND SUN RESISTANCE

Anything on the outside of a building is going to take a beating. Roof vents, Wall Caps, and soffit vents are no different. Powerful UV rays break down unprotected materials over time, causing them to weaken, while hail serves as a battering ram.

Special polymer resins are used in all Primex plastic vents and caps. These keep our products UV-proof so they stay strong and their colour stays sharp. Corrosion-free plastic is also a great choice for wet environments where even galvanized metal will eventually rust, especially if it sustains some light damage.



2. ENHANCED RAINSCREEN COMPATIBILITY

Primex plastic vents and caps are designed to be fundamentally waterproof from the inside out. To eliminate joints and seams our products are made with molded one-piece bases or hoods—depending on the application.

Oversized flanges help create better seals and built-in drip edges help direct water away from the unit. Our vents and caps also come with adapters and extensions that specifically

accommodate the cavity of a rainscreen protected building, ensuring tight seals between the vent and duct.



3. GREATER PEST CONTROL

There's no greater luxury for a cold bird or rodent than an unprotected roof vent. Bird screens on plastic roof vents are molded straight into the unit, so they're not liable to being pulled off at the seams, as in screened metal vents.



4. WHISPER QUIET OPERATION

Plastic dampers and housings operate without the typical clank and clang of metal dampers housed in metal vents. Made from engineered one- and two- piece molds, plastic vents, grilles, and registers are less likely to suffer the harmonic "humming" of their metal counterparts.



5. GREATER COLOUR SELECTION

Plastic Wall Caps and vents are available in a wide variety of colours to match any building's unique palette. Colour dye additives also form an integral part of the entire molded piece, meaning scratches will be less apparent than on painted metal vents or caps.



6. LIGHTWEIGHT AND NO SHARP EDGES

When you're working on a roof or in a hard to reach spot, a lightweight product that doesn't feature the hazardous sharp edges found on most metal vents makes a big difference. Primex plastic products are lightweight and made with clean curved edges to prevent serious injury.

Table of Contents

By Product

ROOF VENTS

RV20 Kit – Low Profile Roof Vent	5
RV28 – Goose Neck Roof Vent.....	6
RVL28 – Low Profile Large Roof Vent	7

WALL CAPS

WC Series – Intake and Exhaust Wall Cap Vents.....	9
WCD/WCT Series – Double/Triple Intake & Exhaust Vents.....	10
WCX Series – Extended Brick Wall Cap.....	11
WCXF – Flat Extended Brick Wall Cap.....	12
WCI – Wall Cap Intake	13
WCL – Low Profile Intake & Exhaust Vents.....	14
SM Series – Surface Mount Wall Vent.....	15
WC4xxNS – Rain Screen Dryer/Exhaust Vent.....	16
DV4 – Dryer/Exhaust Vent.....	16

SOFFIT VENTS

SV Series – Soffit Vent Series.....	17
SV156 – Slab Duct Soffit Vent.....	20
RDV Series – Round Soffit Vent.....	20
SV28 – Soffit Intake and Exhaust Vent	21
SV6x9 – 6" x 9" Soffit Vent.....	22

GRILLES/REGISTERS/DIFFUSERS

RG/B Series – Flushmount/Baseboard Return Grilles	23
WG Series – Adjust-A-Vent Ceiling Diffusers.....	24
WGX Series – True-Flow Ceiling Diffusers	24
DC Series – Terminator Diffuser Collar	25
EB4x90 – 90° Squeeze Elbow.....	26
HR/HRA Series – Classic and Designer Heat Registers	27

TRIM PLATES

201 Series – Standard Trim Plates.....	28
301/401 Series – Single Drip Edge Trim Plates	29
501 Series – Double Drip Edge Trim Plates.....	29

GUTTER ACCESSORIES

MI/MO Series – Gutter Mitre Corners	30
LS401 – Leaf Strainer Outlet.....	31
OL Series – Leaf Strainer Outlets	31
TC Series – Down Spout Tile Covers	32

ACCESSORIES

AP6x9SW – Access Panel	32
------------------------------	----

By Application

DRYER VENTING

RV20KITNS	5
RV28NS.....	6
RVL28NS	7
WCNS Series.....	9
WCXNS Series	11
WC4xxNS	16
DV4	16
SV4.....	17
SV156	20
SV28	21

BATHROOM VENTING

RV20KIT.....	5
RV28.....	6
RVL28.....	7
WC Series.....	9
WCX Series	11
WCXF.....	12
WCL	14
SM Series	15
DV4	16
SV4/5	17
RDV Series.....	20
SV28	21

RANGE VENTING

RV20KIT.....	5
RV28.....	6
RVL28.....	7
WC Series.....	9
WCX Series	11
WCXF.....	12
WCL.....	13
WCL	14
SM Series.....	15
DV4	16

HEAT RECOVERY VENTING (HRV)

RV20KIT.....	5
RV28.....	6
RVL28.....	7
WC Series.....	9
WCI.....	13
WCL	14
SV4/5	17
RDV Series.....	20
SV28	21
DC Series	25
EB4x90	26

INTAKE

WC Series.....	9
WCI.....	13
SM Series.....	15
RDV	20
SV28	21
SV6x9.....	22

COLOUR GUIDE

Primex Roof Vents

Eliminate leaks and maximize water protection

Year after year roofs take a beating—from rain, snow, sun, and pests. Primex plastic roof vents offer durable, watertight solutions that keep homes safe from damaging leaks, birds, and rodents while maximizing proper airflow.

ONE-PIECE MOLDED PLASTIC DESIGN

When it comes to joints and seals it's only a matter of time before water finds a way in. That's why Primex plastic roof vent hoods are molded in one piece—without seams and joints—ensuring a watertight installation every time.

BUILT-IN BIRD SCREEN

An unprotected roof vent is the equivalent of a 5-star hotel to a cold and homeless bird or rodent. And once they're in—either restricting or completely blocking proper airflow—they're not easy to get out. Primex roof vents are made with rugged, integrated bird screens to keep pesky, unwanted guests out for good.

IMPACT-RESISTANT/SUN-PROOF

- Long-lasting durability with specially formulated durable UV-protected polymer resin that's also impact resistant.

VERSATILE

- Multiple colours, sizes, and styles. Choose a low-profile vent for windy environments or a gooseneck vent for maximum snow clearance. All roof vents have a 4" flange.

EASY TO INSTALL

- Plastic designs are lightweight, adaptable across a range of sizes, and free of hazardous sharp edges, making them easy to install in hard-to-reach spots.



New plastic resins – like polypropylene – are much more durable so they can resist hail and heavy snow, or even flying baseballs or hockey pucks! Metal vents, whether they are aluminum or galvanized, are prone to rust. Plastics, on the other hand, can be fully immersed in water.

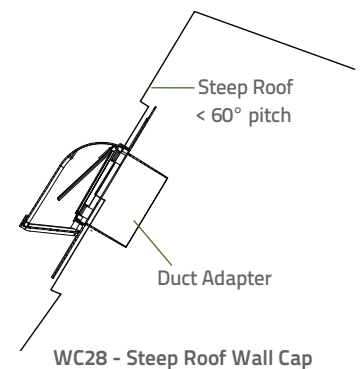
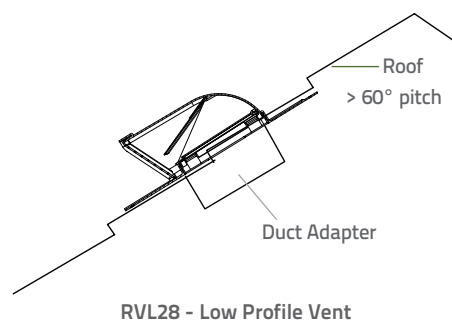
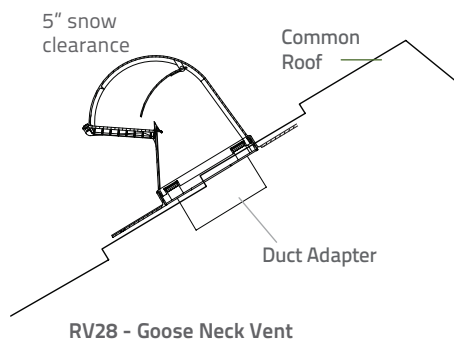

HVAC VENTING

Roof Vents

PRODUCT MODEL CODE

RV20 Kit

Low-Profile Roof Vent

The Primex Low-Profile Roof Vent (RV20) is built for the through-roof exhaust of dryers, bathroom and kitchen fans, stove vents, and intake for furnaces, fresh air make-up, and attic venting.

This patented, durable, watertight roof vent is easily installed and adapted to fit 4, 5 or 6-inch ducting for an aesthetically-pleasing, perfect fit every time.

DIMENSIONS

Hood Size: H: 6.5" / W: 7" / D: 4.9"

FEATURES & BENEFITS

- Patented design eliminates leaky joints and maximizes water protection with one-piece molded hood and oversized 4" flange.
- Aesthetically-pleasing, low-profile styling.
- Molded-in screen to prevent bird and rodent infiltration.
- Long lasting durability with UV-protected, impact-resistant polymer resin.
- Compatible with 4, 5 or 6-inch ducting with included RV456 easy snap-in adapter.
- Simple intake/exhaust conversion via removable damper.
- Quick and easy installation with installer-friendly packaging (vent/adaptor bagged together).
- **NOTE:** For dryer applications use 'no screen (NS)' model.

COLOURS

- Black (25)
- Dark Grey (28)
- Light Grey (31)
- Tan (45)
- Dark Brown (68)

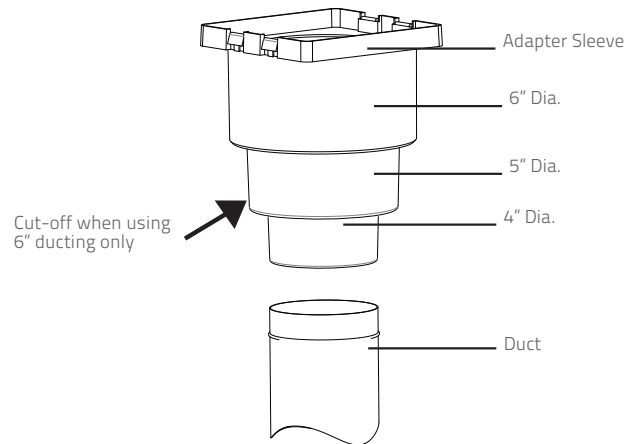
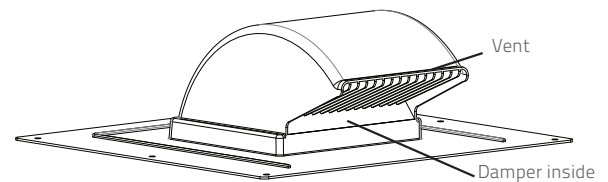

RV20				
PART #	FREE AREA	COLLAR SIZE	DESCRIPTION	PKG
RV20KIT	20.9"	4, 5 & 6"	Roof mount: intake/exhaust vent with screen, damper, RV45 adapter	10/box
RV20KITNS	21.4"	4, 5 & 6"	Roof mount: intake/exhaust vent W/O screen for dryer venting	10/box

The Primex Goose-Neck Roof Vent (RV28) is built for the through-roof exhaust of dryers, bathroom and kitchen fans, stove vents, and intake for furnaces, fresh air make-up, and attic venting.

This patented, seamless, watertight roof vent is easily installed and features a five-inch snow clearance. It can be adapted to fit 4, 5, 6, 7 or 8-inch ducting (with optional adapter) for a perfect fit every time.

DIMENSIONS

Hood Size: H: 15.7"/W: 15.3"/D: 9.5"

FEATURES & BENEFITS

- Provides all-weather ventilation with 5" of additional height for snow clearance and prevents ice damming.
- Maximize inventory turns with single hood size and separate 4 to 8-inch easy snap-in adapters.
- Patented design eliminates leaky joints and maximizes water protection with one-piece, molded hood and oversized 4" flange.
- Ensures watertight installation with oversized flange.
- Resists damage from sun and hail with UV-protected, impact resistant polymer resin.
- Simple intake/exhaust conversion via removable damper.
- Matches 28 Series with the same adapter, including RVL28, WC28, SV28.
- **NOTE:** For dryer applications use 'no screen' (NS) model.

COLOURS

- Black (25)
- Dark Grey (28)
- Light Grey (31)
- Tan (45)
- Dark Brown (68)

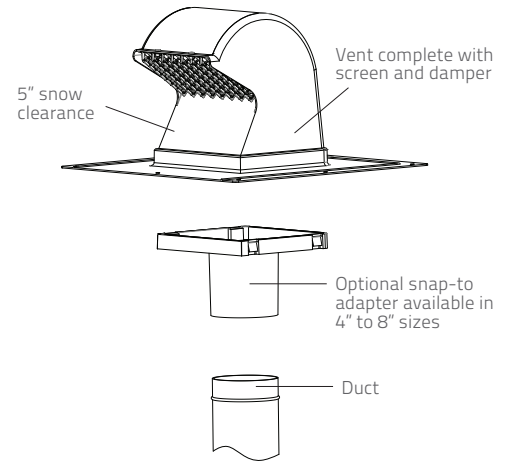

RV28				
PART #	SIZE	FREE AREA	DESCRIPTION	PKG
RV28	7" x 7" x 9.38"	26.5 sq. in.	Exhaust vent with screen	5/box
RV28NS	7" x 7" x 9.38"	31.8 sq. in.	Exhaust vent without screen	5/box
RV28 ADAPTERS				
PART #	SIZE	FREE AREA	DESCRIPTION	PKG
RV28-4	4" diameter	12.6 sq. in.	Duct adapter: 4"	30/box
RV28-5	5" diameter	19.6 sq. in.	Duct adapter: 5"	30/box
RV28-6	6" diameter	26.5 sq. in. 28.3 NS	Duct adapter: 6"	25/box
RV28-7	7" diameter	26.5 sq. in. 31.8 NS	Duct adapter: 7"	25/box
RV28-8	8" diameter	26.5 sq. in. 31.8 NS	Duct adapter: 8"	18/box

HVAC VENTING

Roof Vents

PRODUCT MODEL CODE

RVL28

Low-Profile Large Roof Vent

The Primex Low-Profile Roof Vent (RVL28) is built for the exhaust of dryers, bathroom/kitchen fans, stove vents, and intake for furnaces, fresh air make-up, and attic venting.

The standard configuration of the RVL28 comes with a removable screen and damper. The 4 to 8-inch adapters are sold separately.

DIMENSIONS

Hood Size: H: 10" / W: 10.6" / D: 4.6"

FEATURES & BENEFITS

- Enhances aesthetics with low profile that blends in with roof.
- Maximize inventory turns with single hood size and separate 4 to 8 inch easy snap-in adapters.
- Eliminates leaky joints and maximizes water protection with one-piece, molded hood and oversized 4" flange.
- Oversized flange ensures watertight installation.
- Long lasting durability with UV-protected, impact resistant polymer resin.
- Intake/exhaust conversion via removable damper.
- Matches 28 Series with the same adapter, including RVL28, WC28, SV28.

▪ **NOTE:** For dryer applications 'No screen (NS)' model.

COLOURS

- Snow White (01)
- Taupe (23)
- Black (25)
- Dark Grey (28)
- Light Grey (31)
- Tan (45)
- Dark Brown (68)

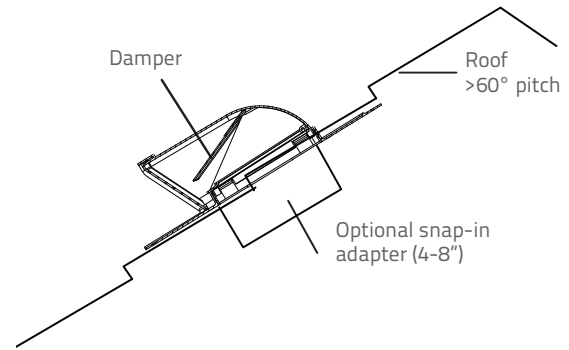

RVL28 - Low Profile Vent

RVL28				
PART #	SIZE	FREE AREA	DESCRIPTION	PKG
RVL28	7.5" x 7.25" x 9.38"	27.8 sq. in.	Roof mount: intake/exhaust vent w/screen	6/box
RVL28NS	7.5" x 7.25" x 9.38"	40.3 sq. in.	Roof mount: intake/exhaust vent w/o screen	6/box
RVL28 ADAPTERS				
PART #	SIZE	FREE AREA	DESCRIPTION	PKG
RV28-4	4" diameter	12.6 sq. in.	Duct adapter: 4"	30/box
RV28-5	5" diameter	19.6 sq. in.	Duct adapter: 5"	30/box
RV28-6	6" diameter	27.8 sq. in. 28.3 NS	Duct adapter: 6"	25/box
RV28-7	7" diameter	27.8 sq. in. 38.5 NS	Duct adapter: 7"	25/box
RV28-8	8" diameter	27.8 sq. in. 40.3 NS	Duct adapter: 8"	18/box

Primex Wall Caps

Keep your rainscreen watertight and leak free

Effective rainscreen is vital for maintaining the integrity of a building. But even after this expensive process, installing the wrong Wall Caps can leave the building envelope just as vulnerable to costly leaks and water damage as before.

Every Primex Wall Cap model features a unique 1.5" extended base that accommodates the gap between the sheathing and cladding of a rainscreened building. This helps eliminate leaks and ensures the integrity of the building envelope by enabling a tight seal between the exterior vent and interior duct.

WATERTIGHT DESIGN

As with the hoods of Primex roof vents, the bases of our Wall Caps are molded in one piece. This means no seams or joints for water to creep through. Coupled with a built-in drip edge and oversized interior flange, each cap is fundamentally watertight from the inside out. The removable hood can be cleaned without compromising the buildings rainscreen.

EXTENSIVE COLOUR SELECTION

Appearance matters and every building has its own unique personality. Molded plastic designs come with the added benefit

of a wider range of colours to choose from. And because the colour dye is added during the manufacturing process it means scratches and day-to-day wear will be less apparent than with painted metal Wall Caps.

RAINSCREEN-COMPATIBLE

- An extended base on every model accommodates the rainscreen cavity, ensuring a watertight seal between sheathing and cladding.

VARIETY OF CHOICE

- Choose from low profile vents for streamlined aesthetics or enhance airflow without increasing the number of leak-prone edges by selecting a double- or triple- vent unit.

ENHANCED DURABILITY

- Made with a specially formulated polymer resin that's UV-protected and impact-resistant.

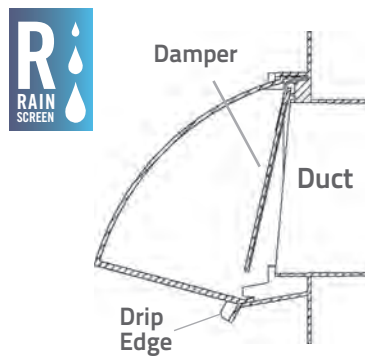

WC Series - Range Hood Vent

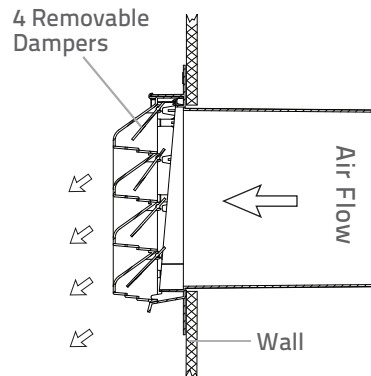

WCL - Low Profile Wall Cap (available only in 7" or 8")



HVAC VENTING

Wall Caps



PRODUCT MODEL CODE

WC Series

Intake and Exhaust Wall Cap Vents

The Primex Wall Cap Series (WC) is ideal for exhaust and intake applications. This includes the through-wall exhaust of dryers, bathroom kitchen fans and stove vents, and the intake for furnaces and fresh air make-up.

This rainscreen-compatible series comes in sizes ranging from 3 to 8 inches and in multiple colours.

FEATURES & BENEFITS

- Compatible with rainscreen applications via extended base, accommodating the cavity between the sheathing and cladding.
- Patented design eliminates leaky joints while maximizing water protection with one-piece molded base and built-in drip edge.
- The integrity of the building envelope is maintained via a removable hood for simple cleaning or replacement.
- The removable damper makes it suitable for intake and exhaust applications.
- Over-sized flange ensures water-tight installation.
- Made with UV-protected durable polymer resin.
- Highly resistant to mechanical impact and includes a built-in bird screen.
- Quick and easy installation.
- NOTE:** For dryer applications use 'no screen (NS)' model.

COLOURS

- Snow White (01)
- Taupe (23)
- Black (25)
- Dark Grey (28)
- Light Grey (31)
- Tan (45)
- Dark Brown (68)



WC31031 - Light Grey Range Hood



WC631 - Light Grey

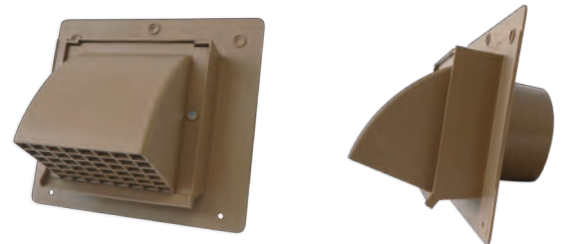

WC4 - Brown

WC SERIES

W/BIRD SCREEN	W/O BIRD SCREEN	COLLAR SIZE	FREE AREA	DESCRIPTION	PKG
WC3	WC3NS	3"	7.7 sq. in.	For use with 3" dia. ducting	25/box
WC4	WC4NS	4"	9.5 sq. in.	For use with 4" dia. ducting	25/box
WC5	WC5NS	5"	19.6 sq. in.	For use with 5" dia. ducting	10/box
WC6	WC6NS	6"	28.3 sq. in.	For use with 6" dia. ducting	10/box
WC7	WC7NS	7"	38.5 sq. in.	For use with 7" dia. ducting	2/box
WC8	WC8NS	8"	46.8 sq. in.	For use with 8" dia. ducting	2/box

WC310 RANGE HOODS

PART #	DUCT BOOT	FREE AREA	DESCRIPTION	PKG
WC310	3" x 10"	30.2 sq. in.	Wall Cap Vent: use with 3" x 10" register boot or slab duct	18/box
WC310K	3.25" x 10"	30.2 sq. in.	Range Hood Vent: use with 3.25" x 10" kitchen transition boot or slab duct	18/box



The Primex Double and Triple intake and exhaust Vents (WCD/WCT) are ideal for exhaust and intake applications. This includes the through-wall exhaust of dryers, bathroom kitchen fans and stove vents, and the intake for furnaces and fresh air make-up.

These vents are custom configurable with multiple sizes and either screened or non-screened.

Ask us about custom sizes.



WCD531 - Light Grey



WCD545 - Tan

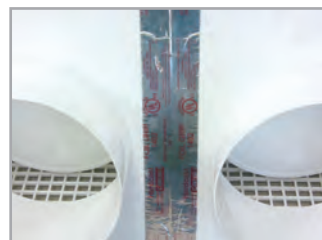

Connecting tape provides permanent joint and seal.

FEATURES & BENEFITS

- Compatible with rainscreen applications via extended base, accommodating the cavity between the sheathing and cladding.
- Patented design eliminates leaky joints, while maximizing water protection with one-piece molded base and built-in drip edge.
- The integrity of the building envelope is maintained via a removable hood for simple cleaning or replacement.
- Suitable for intake and exhaust applications.
- Over-sized flange ensures water-tight installation.
- Made with UV-protected durable polymer resin.
- Highly resistant to mechanical impact and includes a built-in bird screen.
- Quick, easy installation with an assembled base.
- **NOTE:** As a custom manufactured product, these vents are non-returnable. For dryer applications use 'no screen' (NS) model.

COLOURS

- Snow White (01)
- Taupe (23)
- Black (25)
- Dark Grey (28)
- Light Grey (31)
- Tan (45)
- Dark Brown (68)



WCD/WCT WALL CAPS

PART #	FREE AREA	DESCRIPTION	PKG
WCD4	2 x 9.5 sq. in	Double Wall Cap will fit 4" diameter ducting	10/box
WCD5	2 x 19.6 sq. in	Double Wall Cap will fit 5" diameter ducting	6/box
WCD6	2 x 25 sq. in	Double Wall Cap will fit 6" diameter ducting	5/box
WCT4	3 x 9.5 sq. in	Triple Wall Cap will fit 4" diameter ducting	10/box
WCT5	3 x 19.6 sq. in	Triple Wall Cap will fit 5" diameter ducting	1/box
WCT6	3 x 25 sq. in	Triple Wall Cap will fit 6" diameter ducting	1/box

HVAC VENTING

Wall Caps

PRODUCT MODEL CODE

WCX Series

Extended Brick Wall Cap

The Primex Extended Brick Wall Cap Series (WCX) increases the depth of the Wall Cap for use on the outside of brick and masonry structures. Maintain a consistent look throughout your Wall Caps when paired with the WC Series for non-brick applications.

Available in 4, 5, and 6-inch duct sizes, this rainscreen compatible unit provides excellent, long term water protection.

DIMENSIONS

Hood Size: H: 7.8" / W: 8.1" / D: 4.5"

FEATURES & BENEFITS

- Suitable for brick and masonry walls and intake or exhaust applications.
- Compatible with rainscreen applications via extended base, accommodating the cavity between the sheathing and cladding.
- Patented design eliminates leaky joints, while maximizing water protection with one-piece molded base, built-in drip edge and oversized flange to ensure water-tight installation.
- The integrity of the building envelope is maintained via a removable hood for simple cleaning or replacement.
- Made with UV-protected durable polymer resin.
- Highly resistant to mechanical impact and includes a built-in bird screen.
- Quick and easy installation.
- Hoods match WC Series Wall Caps.
- **NOTE:** For dryer applications use 'no screen' (NS) model.

COLOURS

- Snow White (01)
- Taupe (23)
- Black (25)
- Dark Grey (28)
- Light Grey (31)
- Tan (45)
- Dark Brown (68)

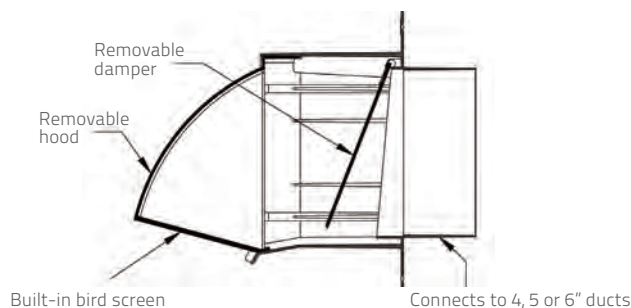
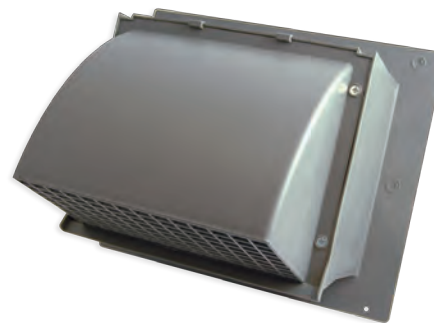

WCX SERIES

PART #	COLLAR SIZE	FREE AREA	DESCRIPTION	PKG
WCX4	4"	12.6"	4" extended Wall Cap	6/box
WCX5	5"	19.6"	5" extended Wall Cap	6/box
WCX6	6"	28.3"	6" extended Wall Cap	6/box



The Primex Flat Extended Brick Wall Cap (WCXF) increases the depth of the Wall Cap for use on the outside of brick and masonry structures while maintaining a very low profile.

Available in 4, 5, and 6-inch duct sizes, this rainscreen compatible unit provides excellent, long term water protection.

DIMENSIONS

Hood Size: H: 7.5" / W: 8.9" / D: 5.1"

FEATURES & BENEFITS

- Suitable for brick and masonry walls and intake or exhaust applications.
- Compatible with rainscreen applications via extended base, accommodating the cavity between the sheathing and cladding.
- Patented design eliminates leaky joints, while maximizing water protection with one-piece molded base and built-in drip edge.
- The integrity of the building envelope is maintained via a removable grille for simple cleaning or replacement.
- Over-sized flange ensures water-tight installation.
- Made with UV-protected durable polymer resin.
- Highly resistant to mechanical impact and includes a built-in bird screen.
- Quick and easy installation.

COLOURS

- Snow White (01)
- Taupe (23)
- Black (25)
- Dark Grey (28)
- Light Grey (31)
- Tan (45)
- Dark Brown (68)

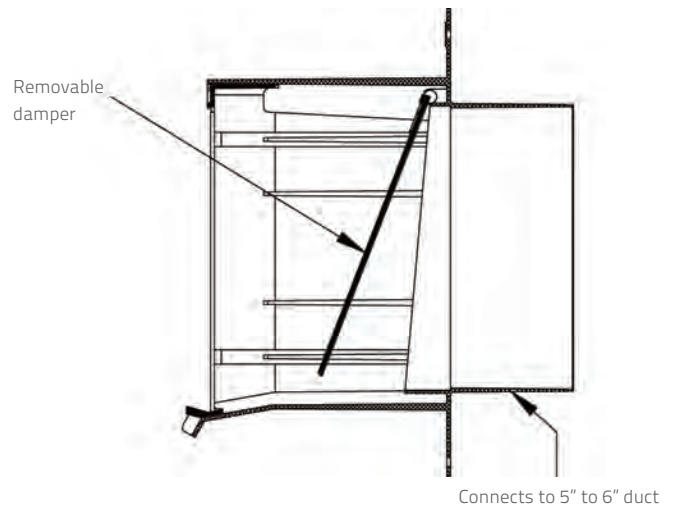

WCXF SERIES				
PART #	COLLAR SIZE	FREE AREA	DESCRIPTION	PKG
WCXF4	4"	12.6"	4" extended Wall Cap	9/box
WCXF5	5"	19.6"	5" extended Wall Cap	9/box
WCXF6	6"	28.3"	6" extended Wall Cap	9/box

HVAC VENTING

Wall Caps



PRODUCT MODEL CODE

WCI
Wall Cap Intake

The Primex Wall Cap Intake (WCI) has been designed with many of the weather beating features as our WC series of Wall Caps. This air intake unit incorporates the best features of our patented Wall Cap with a low-profile intake hood.

Designed to work as an intake vent for furnaces, gas appliances, fireplaces, hot water tanks, air conditioners and anywhere else fresh air make-up is required. Available in 5 or 6 inches.

DIMENSIONS

H: 9.9" / W: 11.9" / D: 1.5"

FEATURES & BENEFITS

- Compatible with rainscreen applications via extended base, accommodating the cavity between the sheathing and cladding.
- Eliminates leaky joints while maximizing water protection with seamless base and built-in drip edge.
- The integrity of the building envelope is maintained via a removable grille for simple cleaning or replacement.
- Over-sized flange ensures water-tight installation.
- Made of durable UV-protected durable polymer resin.
- Highly resistant to mechanical impact and includes a built-in bird screen.
- Quick and easy installation.
- **NOTE:** Ideal for intake applications where it is sheltered by a soffit.



COLOURS

- Snow White (01)
- Taupe (23)
- Black (25)
- Dark grey (28)
- Light Grey (31)
- Tan (45)
- Dark Brown (68)

WCI SERIES

PART #	COLLAR SIZE	FREE AREA	DESCRIPTION	PKG
WCI5	5"	19.6"	Wall Cap 5", intake	16/box
WCI6	6"	28.3"	Wall Cap 6", intake	16/box

Why Plastic?

COMMON TYPES OF PLASTICS

The two most common resins used in injection-molded products are polypropylene and polystyrene. While both of these feature similar characteristics such as strength, aesthetics and ease of recyclability, they do differ in some key characteristics.

POLYPROPYLENE: Wall caps, soffit vents and roof vents require more durable, flexible and Ultraviolet-tolerant (UV) plastic. polypropylene offers long-term environmental protection and durability.

POLYSTYRENE: Polystyrene is more rigid than polypropylene and as such isn't as vulnerable to warping from heat. With applications that handle heated airflow such as return air grilles and registers, polystyrene offers excellent heat durability at low cost.

Both polypropylene and polystyrene are quickly manufactured for fast turnaround and they are both lightweight, which can reduce shipping costs and increase ease-of-installation.

Plastics are also easily modified during installation. Need to trim of an edge or round a corner to fit with a baseboard? Modifications are quick and easy with plastics.

- DURABLE
- LIGHTWEIGHT
- RUST-PROOF
- HEAT-RESISTANT
- AESTHETICALLY-PLEASING
- AFFORDABLY PRICED



The Primex Low Profile Intake and Exhaust Vents (WCL Series) eliminate leaky joints while maximizing water protection with a one-piece molded base and built-in drip edge.

These vents feature an attractive low profile design and fit 7" and 8" diameter ducts.

PRODUCT DIMENSIONS

Hood Size: H: 10.25" /W: 12.3" /D: 1.7"

FEATURES & BENEFITS

- Compatible with rainscreen applications via extended base, accommodating the cavity between the sheathing and cladding.
- Enhances aesthetics with low profile that blends with the installation location.
- Suitable for intake and exhaust applications where a low profile is preferred.
- Over-sized flange ensures water-tight installation.
- The integrity of the building envelope is maintained via a removable grille for simple cleaning or replacement.
- Made with UV-protected durable polymer resin.
- Highly resistant to mechanical impact and includes a built-in bird screen.
- Quick and easy installation.

COLOURS

- Snow White (01)
- Light Grey (31)
- Taupe (23)
- Tan (45)
- Black (25)
- Dark Brown (68)
- Dark Grey (28)

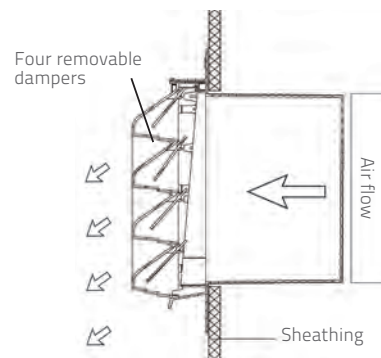

WCL			
PART #	FREE AREA	DESCRIPTION	PKG
WCL7	38.5"	Low profile WC, 7" dia. duct	4/box
WCL8	50.3"	Low profile WC, 8" dia. duct	4/box

5 Ways Primex Wall Caps Protect the Building Envelope



1. EXTENDED BASE FOR A TIGHTER SEAL
The WC Series of Primex Wall Caps come with a 1.5" extended base (5" for brick), which accommodates the cavity in between the sheathing and cladding of a rainscreened building. This ensures a tight, firm seal with no gaps between the exterior vent and internal duct.

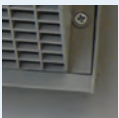

2. BUILT-IN DRIP EDGE AND DRAINAGE CHANNEL
For added protection, our Wall Caps are molded with built-in drip edges and drainage channels to efficiently move water away from the vent and building.

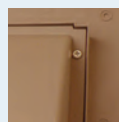

3. PATENTED REMOVABLE HOOD
Easily removable hoods make cleaning and maintaining our Wall Caps quick and easy—all without breaking the seal of the building envelope.



4. OVERSIZED MOUNTING FLANGE
To increase the degree of water protection and decrease the possibility of leaks due to poor sealing, our Wall Caps are designed with oversized mounting flanges for greater overlap.



5. SINGLE PIECE BASE
Unlike most metal alternatives, our molded one-piece bases mean no seams or joints for water to find, exploit, and slowly creep its way through.

HVAC VENTING

Wall Caps



PRODUCT MODEL CODE

SM Series

Surface Mount Wall Vents

The Primex Surface Mount Wall Vent (SM Series) is the perfect replacement for existing bathroom or range hood exhaust terminations. The SM Series is easy to install and aesthetically-pleasing.

The seamless, low-profile, one-piece design accommodates standard 4-6 inch ducting. UV-stabilized polymer resin offers long-lasting protection while reducing leaks.

FEATURES & BENEFITS

- Eliminates leaky joints while maximizing water protection with one-piece, seamless design.
- Suitable for intake and exhaust applications via removable damper.
- Spring loaded damper reduces wind flapping.
- Made with UV-stabilized durable polymer resin.
- Highly resistant to mechanical impact.
- Surface mounted for quick and easy installation.
- Removable screen for dryer venting applications.

COLOURS

- Snow White (01)
- Light Grey (31)
- Taupe (23)
- Dark Brown (68)



Spring loaded damper reduces flapping



Low profile and aesthetically pleasing design

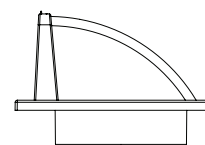
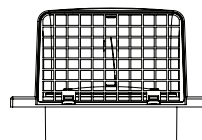
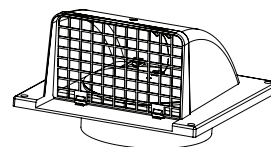
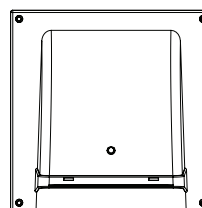

WC28

PART #	SIZE	FREE AREA	DESCRIPTION	PKG
SM4	4" Dia.	9.7 sq. in.*	Surface mount vent	24/box
SM5	5" Dia.	19.3 sq. in.*	Surface mount vent	10/box
SM6	6" Dia.	19.3 sq. in.*	Surface mount vent	10/box

*Free area does not account for spring loading.

PRODUCT MODEL CODE

WC4xxNS

Rain Screen Dryer/Exhaust Vent



HVAC VENTING Wall Caps

The Primex Dryer/Exhaust Vent (WC4xxNS) is a screenless solution for 4-inch dryer duct venting. This rainscreen compatible vent eliminates leaky joints through its one-piece base and built-in drip edge.

A removable hood allows for easy cleaning or replacement.

DIMENSIONS

Hood Size: H: 5.6" / W: 5.6" / D: 3.1"

FEATURES & BENEFITS

- Compatible with rainscreen applications via extended base, accommodating the cavity between the sheathing and cladding.
- Eliminates leaky joints while maximizing water protection with one-piece molded base and built-in drip edge.
- The integrity of the building envelope is maintained via a removable hood for simple cleaning or replacement.
- Suitable for intake and exhaust applications.
- Over-sized flange ensures water-tight installation.
- Made with UV-protected durable polymer resin.
- Highly resistant to mechanical impact.
- Quick and easy installation.
- Adaptable to dryer venting applications.
- No-screen models are available from 3-8" (refer to page 9)
- **NOTE:** Can be used as surface mount retrofit.



COLOURS

- Snow White (01)
- Taupe (23)
- Black (25)
- Dark Grey (28)
- Light Grey (31)
- Tan (45)
- Dark Brown (68)

WC4XXNS				
PART #	COLLAR	FREE AREA	DESCRIPTION	PKG
WC4xxNS	4"	12.6"	4" Dryer/exhaust N/S	25/box

PRODUCT MODEL CODE

DV4

Dryer/Exhaust Vent

HVAC VENTING Wall Caps

The Primex Dryer/Exhaust Vent (DV4) is a surface-mount, durable, and aesthetically-pleasing solution for venting residential dryers.

The low-profile, one-piece design accommodates standard 4-inch ducting. UV-stabilized polymer resin offers long-lasting protection while eliminating leaky seams on the vent hood.

DIMENSIONS

Hood Size: H: 7.1" / W: 7.1" / D: 3.3"

FEATURES & BENEFITS

- Low-profile, surface-mount one piece design.
- Accommodates 4" ducting.
- No leaky seams on the vent hood.
- Made from UV-stabilized polymer resin.
- No screen to allow for lint exhaustion.
- Durable, long-lasting.



COLOURS

- Snow White (01)
- Taupe (23)
- Tan (45)
- Dark Brown (68)

DV4				
PART #	SIZE	FREE AREA	DESCRIPTION	PKG
DV4	4"	12.6 sq. in.	Dryer/Exhaust Vent	24/box
DV5	4"	12.6 sq. in.	Dryer/Exhaust Vent	10/box
DV6	4"	12.6 sq. in.	Dryer/Exhaust Vent	10/box

Primex Soffit Vents

Vent your soffit while eliminating pests and leaks

Clanging metal dampers, trespassing rodents, clogged air vents, and unexplained heat loss in the home can often be traced back to the selection and installation of the wrong soffit vent.

Primex plastic soffit vents come in a variety of sizes and styles to suit the unique needs of each particular installation. Removable plastic dampers reduce noise, keep out pests, and allow vents to be easily switched over for intake usage.

VERSATILE AESTHETICS

Low profile and unobtrusive, Primex soffit vents blend in and operate quietly. Their simple design and neutral colours compliment the look of any building.

LEAK-PROOF DESIGN

Molded one and two-piece plastic designs mean Primex soffit vent hoods have no seams, providing maximum water protection.

RUSTPROOF AND SUN-PROOF

- Specially formulated polymer resin provides enhanced protection from damaging UV rays, and rustproof plastic design ensures long-lasting durability.

QUIET OPERATION

- Unlike the sharp clangs experienced with their metal counterparts, plastic soffit vents with plastic dampers provide steady, quiet airflow.



HVAC VENTING Soffit Vents

PRODUCT MODEL CODE

SV Series
Soffit Vent Series

The Primex Soffit Vent Series (SV Series) consists of low-profile, durable exhaust solutions for a range of applications.

The UV-stabilized, one-piece design eliminates leaky seams. A one-way damper prevents rodents and debris from entering the home while effectively exhausting moisture.

The SV Series offers two models for standard 4 or 5-inch ducting and an aesthetically-pleasing termination.

FEATURES & BENEFITS

- Low profile, one-piece design is less obtrusive than traditional vents.
- Choose from two different models for either 4" or 5" ducting.
- Can be used in new or retrofit applications.
- No need to penetrate the roof or walls.
- No leaky seams on the vent hood.
- Made from durable, UV-stabilized polymer resin.
- Lightweight and easy to install.
- Available in Snow White and Taupe.



COLOURS

- Snow White (01)
- Taupe (23)

SV SERIES				
PART #	SIZE	FREE AREA	DESCRIPTION	PKG
SV4	4"	12.6 sq. in.	Soffit vent w/damper	24/box
SV5	5"	13.3 sq. in.	Soffit vent w/damper	24/box
SV6	6"	19.33 sq. in.	Soffit vent w/damper	10/box

EXTERIOR VENTING PRODUCTS

Soffit Vents

The low profile of the SV series vents make them ideal for tucking away under the soffit. The smooth curves help to push air out and away from the soffit, dispersing moisture away from the building.

The SV28 series is adaptable for 4-8 inch ducting, making it particularly useful for venting larger range hoods.

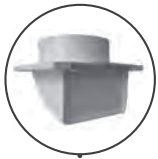

Roof Jacks

Primex offers a variety of roofing vents designed for extreme weather protection. Large flanges and seamless mould design protect from leaks and durable, engineered plastic resin provides UV protection and resists denting.

The RV28 Gooseneck provides 5 inches of snow clearance, while the RV20 Kit comes with a 4/5/6 inch step up adapter and offers low profile, pleasing aesthetics.



Wall Caps

The WC series of Wall Caps are the simply the best in the business. With oversized flanges, and seamless design they protect from moisture like no other vent. The patented removable hood means you can clean the duct without compromising the building envelope. High quality, durable resin provides long life and protection from fading, cracking and dents.

Engineered for rainscreen compatibility the WC series is available in a variety of colours and configurations. Options for brick facades, range hood ducting, flat or curved hood, intake or exhaust, 4-8 inch duct compatibility and multi-cap configurations make the WC series the most versatile wall vent in the industry.



Other

- Interior grilles, diffusers and registers in a variety of colours and sizes.
- Trim plates for light fixtures, hose bibs and electrical outlets.
- Gutter accessories - mitre corners, downspout tile covers and leaf strainers.



ENVELOPE AND HVAC SYSTEMS MEET

NO OTHER HVAC VENTING COMPANY KNOWS MORE ABOUT THE RELATIONSHIP BETWEEN THE BUILDING ENVELOPE AND HVAC SYSTEMS.

Living in a temperate rainforest on Canada's wet west coast, we've seen a lot of rain! We know how difficult and important it is to maintain the integrity of a building envelope under constant attack from moisture. Our range of engineered, rainscreen-approved plastic products stand up to almost anything Mother Nature can throw at them.

SOLUTIONS FOR ALL YOUR ACTIVE VENTING NEEDS

Clothes Dryer

The buildup of lint, mould and debris inside vents and ducts can restrict airflow. That causes appliances to operate inefficiently. It may also increase the pollutants in a home and degrade air quality. In the case of a dryer vent, lint can build up and create a significant fire hazard.

A well-designed vent includes a removable hood which allows a homeowner or contractor access to the duct behind it without having to disturb the building envelope.



Bathroom Fan

A bathroom vent should move air away from nearby passive vents, which could allow moisture to re-enter the home and gather in the walls or rafters. It should incorporate a one piece design, and form a watertight seal with the roof or wall material around it. Primex offers a range of vents for effectively exhausting moisture from the structure.



Range Hood

Installation of an exhaust fan above a stove is a critical step in creating safe and enjoyable kitchens. Ideally, those fans will exhaust smells, smoke, water vapour and other gases to the outside. The idea is simple, but choosing the right materials to include in your design is not always easy.



PRODUCT MODEL CODE

RDV Series

Round Soffit Vent Series

HVAC VENTING

Soffit Vents

The Primex Round Soffit Vent Series (RDV) is a versatile venting solution for either intake or exhaust applications.

This series comes in sizes ranging from 2 to 6 inches and provides a secure fit with UV-stabilized polymer resin.

Use with the Primex 4" Squeeze Elbow for installations where space is limited (RDV4S only).

FEATURES & BENEFITS

- Helps prevent peeling paint by removing moisture from wall cavities.
- Extra long collar for better hose or duct connection.
- Molded-in mesh bug screen.
- Secure friction fit.
- Made from durable, one-piece molded plastic.
- Quick and easy installation.
- Pair with optional Primex 4-inch Squeeze Elbow (EB4x90) for 2x4 stud installation.

COLOURS

- Snow White (01)

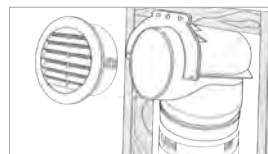

4" Round Vent installed with Primex's 'Squeeze Elbow' EB4x90

RDV SERIES				
PART #	SIZE	FREE AREA	DESCRIPTION	PKG
RDV2S	2"	1.1 sq. in.	Round, screen soffit	50/bag
RDV4S	4"	4 sq. in.	Round, screen soffit	70/box
RDV5S	5"	6.4 sq. in.	Round, screen soffit	50/box
RDV6S	6"	10.3 sq. in.	Round, screen soffit	30/box

PRODUCT MODEL CODE

SV156

Slab Duct Soffit Vent

HVAC VENTING

Soffit Vents

The Primex Slab Duct Soffit Vent (SV156) is a low profile, solution for slab duct venting. The seamless hood eliminates leaky joints and provides excellent water protection. The one-piece base fits most brands of slab duct. Building owners can realize substantial savings with fewer cleanings required than metal terminations.

PRODUCT DIMENSIONS

Hood Size: H: 5.25"/W: 12.5"/D: 2.5"

FEATURES & BENEFITS

- Molded one piece base.
- Fits most brands of slab duct.
- Removable damper for intake applications.
- Manufactured to replace the standard metal discharge hoods currently available.
- No need to penetrate the roof or walls.
- Low profile one-piece molded hood eliminates leaky joints and maximizes water protection.
- Made from UV-stabilized polymer resin.
- Hoods are easily cleaned or replaced.
- Quick and easy installation.



COLOURS

- Snow White (01)
- Light Grey (31)

SV156			
PART #	FREE AREA	DESCRIPTION	PKG
SV156	27.8 sq. in.	Slab duct soffit vent	12/box

HVAC VENTING

Soffit Vents

PRODUCT MODEL CODE

SV28

Soffit Intake and Exhaust Vent

The Primex Soffit Intake and Exhaust Vent (SV28) is ideal for 4 to 8 inch ducts that require venting with a damper.

This versatile unit allows for the termination of kitchen, bath, and dryer vents. The SV28 is designed to prevent pests, birds and rodents from entering the home. Multiple choices depending on the application: no-screened, with damper and screen, with screen only as intake, with damper and no screen as dryer vent.

DIMENSIONS

Hood Size: H: 10" / W: 10.5" / D: 4.375"

FEATURES & BENEFITS

- Low profile, one-piece molded hood eliminates leaky joints and provides maximum water protection.
- Vents odor and moisture away from the home.
- Optional screen and removable damper.
- Available for intake or exhaust applications.
- Optional snap-in adapters ensure a tight seal.
- Quick and easy to install.
- Made with UV-protected durable polymer resin.
- Available in Snow White and Taupe.
- Matches 28 Series, including RVL28, WC28, SV28.
- **NOTE:** For dryer applications use 'no screen' (NS) model.

COLOURS

- Snow White (01)
- Taupe (23)

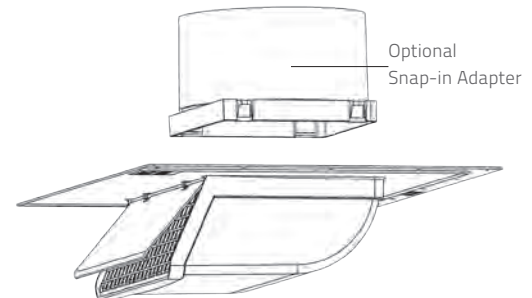

SV28				
PART #		FREE AREA	DESCRIPTION	PKG
SV28		27.6 sq. in.	Soffit vent w/screen	6/box
SV28NS		40.3 sq. in.	Soffit vent w/o screen	6/box
SNAP-IN ADAPTERS				
PART #	COLLAR	FREE AREA	DESCRIPTION	PKG
RV28-4	4"	12.6 sq. in.	Duct adapter: 4"	30/box
RV28-5	5"	19.6 sq. in.	Duct adapter: 5"	30/box
RV28-6	6"	27.6 sq. in / 28.3	Duct adapter: 6"	25/box
RV28-7	7"	27.6 sq. in / 38.5	Duct adapter: 7"	25/box
RV28-8	8"	27.6 sq. in / 40.3	Duct adapter: 8"	18/box

The Primex 6x9 Soffit Vent (SV6x9) is a versatile venting solution ideal for attic ventilation, trailer skirting, and anywhere additional air flow is needed such as a ventilated access cover.

This durable vent includes a molded-in mesh screen and is quickly and easily installed to last.

DIMENSIONS

Size: H: 6" / W: 9"

FEATURES & BENEFITS

- Molded-in mesh screen.
- Includes two installation screws.
- The SV6x9 may be installed with or without the access frame.
- No need to penetrate the roof or walls.
- Made from UV-stabilized polymer resin.
- Easy to install.
- Available in two colours.

COLOURS

- Snow White (01)
- Taupe (23)

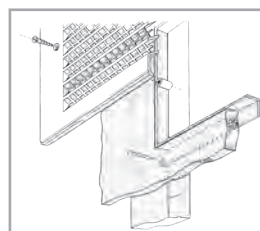
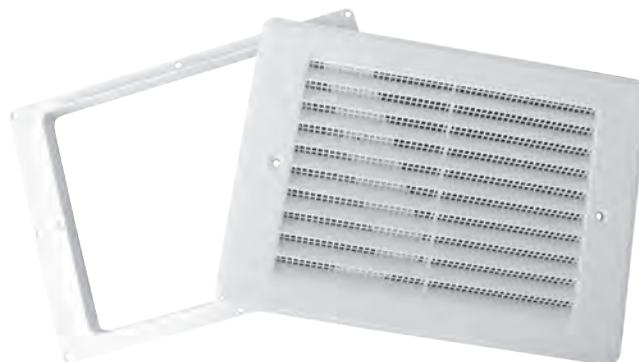

Reverse Mount Installation

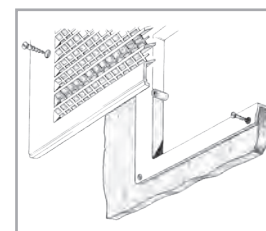

Flushmount Installation

SV6X9			
PART #	FREE AREA	DESCRIPTION	PKG
SV6x9	15.7 sq. in.	Vent kit: screen/access frame	22/box

Primex Grilles/Registers/Diffusers

Finish ducts and vents with clean whisper quiet outlets

Return-air grilles, heat registers, and air diffusers should blend in seamlessly and noiselessly with the rest of the interior, as if they are not even there. Primex plastic grilles, registers, and diffusers won't warp from heat and, unlike metal, won't produce a harmonic 'hum' noise.

DURABLE AND HEAT-RESISTANT

Primex registers, grilles and diffusers are made with heat-resistant polystyrene, which ensures they stand up to the high temperatures in HVAC ducts. This prevents warping and increases durability.

CHOICE OF STYLES

Ultra-thin flushmount grilles and slightly thicker baseboard grilles are available for return-air applications, while heat registers are available in either classic or designer styles.

EASY TO INSTALL

- Preset collars and 90° squeeze elbows make installing any size of diffuser quick and easy even in tight spaces, while return air grilles come with included screws.

MULTIPLE SIZES

- Choose from 22 different sizes of return air grilles, 9 different sizes of heat registers, and 5 different sizes of ceiling diffusers.

WHISPER QUIET

- Specially engineered Return Grilles with molded plastic design eliminate the harmonic 'hum' often associated with metal vents.

HVAC VENTING

Grilles

PRODUCT MODEL CODE

RG/B Series

Baseboard/Flushmount Return Grilles

The Primex Baseboard/Flushmount Return Grilles (RG/B Series) provides an aesthetically-pleasing finish to a range of return air applications.

Choose from 19 different sizes in flushmount or baseboard depth for a clean profile in Snow White colour.

Easy to install, easy to remove and clean, the RG/B Series offers a long-lasting HVAC venting solution in durable polymer resin.

FEATURES & BENEFITS

- Thirteen available sizes in 6", and nine available sizes in 8" heights.
- Two models: Flushmount (RG) 3/8" depth; Baseboard (RGB) 3/4" depth.
- Increased mounting strength with additional center screw hole on grilles 18" and larger.
- Eliminates harmonic noise hum often produced by metal grilles.
- Easy to remove and clean.
- Made from high-strength, durable polymer resin.
- Includes painted screws.

COLOUR

- Snow White (01)



RG SERIES

PART # (BASEBOARD)	COLLAR SIZE (FLUSHMOUNT)	SIZE	FREE AREA	DESCRIPTION	RGB PKG	RG PKG
RGB606	RG606	6" x 6"	22.7 sq. in.	Grille with 2 screws	20/box	40/box
RGB706	RG706	7" x 6"	26.3 sq. in.	Grille with 2 screws	20/box	40/box
RGB806	RG806	8" x 6"	30.0 sq. in.	Grille with 2 screws	20/box	40/box
RGB906	RG906	9" x 6"	34.0 sq. in.	Grille with 2 screws	20/box	40/box
RGB106	RG106	10" x 6"	37.7 sq. in.	Grille with 2 screws	20/box	40/box
RGB116	RG116	11" x 6"	41.3 sq. in.	Grille with 2 screws	20/box	40/box
RGB126	RG126	12" x 6"	45.4 sq. in.	Grille with 2 screws	20/box	40/box
RGB136	RG136	13" x 6"	49.0 sq. in.	Grille with 2 screws	20/box	40/box
RGB146	RG146	14" x 6"	52.7 sq. in.	Grille with 2 screws	20/box	40/box
RGB186	RG186	18" x 6"	68.0 sq. in.	Grille with 3 screws	10/box	20/box
RGB206	RG206	20" x 6"	75.3 sq. in.	Grille with 3 screws	10/box	20/box
RGB246	RG246	24" x 6"	90.8 sq. in.	Grille with 3 screws	10/box	20/box
RGB306	RG306	30" x 6"	113.5 sq. in.	Grille with 3 screws	10/box	20/box
RGB608	RG608	6" x 8"	113.5 sq. in.	Grille with 2 screws	20/box	36/box
RGB808	RG808	8" x 8"	30.3 sq. in.	Grille with 2 screws	20/box	36/box
RGB108	RG108	10" x 8"	60.5 sq. in.	Grille with 2 screws	20/box	36/box
RGB128	RG128	12" x 8"	60.5 sq. in.	Grille with 2 screws	20/box	36/box
RGB148	RG148	14" x 8"	70.2 sq. in.	Grille with 2 screws	20/box	36/box
RGB188	RG188	18" x 8"	90.7 sq. in.	Grille with 3 screws	10/box	18/box
RGB208	RG208	20" x 8"	100.4 sq. in.	Grille with 3 screws	10/box	18/box
RGB248	RG248	24" x 8"	121.0 sq. in.	Grille with 3 screws	10/box	18/box
RGB308	RG308	30" x 8"	151.2 sq. in.	Grille with 3 screws	10/box	18/box

PRODUCT MODEL CODE

WG Series

Adjust-A-Vent Ceiling Diffusers

HVAC VENTING Diffusers

The Primex Adjust-A-Vent Ceiling Diffusers (WG Series) are durable, adjustable air supply or exhaust vents.

This ceiling or wall mountable series provides whisper quiet airflow in an unobtrusive and aesthetically pleasing housing.

Pair it with the Primex diffuser collar (DC Series) or the EB4x90 for simple, accurate installation.



WG401

WG501

WG601

FEATURES & BENEFITS

- Dual flow: whisper quiet air supply or exhaust with lock nut to fine tune air flow from 0-100%.
- Strong stainless steel grip clip provides snug fit.
- Extra thick foam gasket allows for tight seal on uneven surfaces and provides quiet air flow.
- Extra long collar simplifies installation (WG401XB).
- Long-lasting durability with impact resistant, polymer resin.
- WG401 vent (with shorter collar) is compatible with Primex's squeeze elbow accessory EB4x90.
- Easy to install and remove.

COLOURS

- Snow White (01)

WG SERIES				
PART #	SIZE	FREE AREA	DESCRIPTION	PKG
WG401	4"	5.5 sq. in.	Shorter collar for use w/EB4x90	25/box
WG401XB	4"	5.5 sq. in.	Adjustable diffuser	25/box
WG501	5"	9.9 sq. in.	Adjustable diffuser	25/box
WG601	6"	11.4 sq. in.	Adjustable diffuser	25/box

HVAC VENTING Diffusers

PRODUCT MODEL CODE

WGX Series

True-Flow Ceiling Diffusers

The Primex True-Flow Ceiling Diffusers (WGX Series) are durable, highly-adjustable air supply or exhaust vents.

The ceiling mountable Series provides whisper-quiet airflow in an unobtrusive and aesthetically pleasing housing. Pair the 4-inch (WGX4S) model with the EB4x90 and the DC Series diffuser collar for simple, accurate installation in tight spaces.



FEATURES & BENEFITS

- Dual flow: whisper quiet air supply or exhaust with four-wing screw to adjust air flow from 0-100%.
- Increased air flow over the WG Series.
- Added security of mounting screws through base flange.
- Snap-on trim ring to hide mounting screws and hole trim is included.
- Long-lasting durability with UV-protected, impact resistant, polymer resin.
- WGX4S vent (with shorter collar) is compatible with Primex's squeeze elbow accessory (EB4x90) and 4-inch diffuser sleeve (DS Series).
- Easy to install and remove.

COLOURS

- Snow White (01)

WGX SERIES				
PART #	SIZE	FREE AREA	DESCRIPTION	PKG
WGX4	4"	10.5 sq. in.	Adjustable diffuser	25/box
WGX4S	4"	10.5 sq. in.	Adjustable diffuser w/short base for EB4x90	25/box
WGX5	5"	16.9 sq. in.	Adjustable diffuser	25/box
WGX6	6"	25.1 sq. in.	Adjustable diffuser	25/box
WGX7	7"	35.5 sq. in.	Adjustable diffuser	15/box
WGX8	8"	45.5 sq. in.	Adjustable diffuser	15/box

HVAC VENTING Diffusers

PRODUCT MODEL CODE

DC Series
Terminator Diffuser Collar

Terminator™ (DC Series) from Primex is a termination for round ducting and a collar for diffusers and grilles in air distribution systems. The strong, industrial-grade plastic is durable and lightweight.

Terminator is the solution to sloppy, inaccurate termination of HVAC ducting. This unique product is ideal for HRV, ERV, and in-line fan supply and exhaust terminations.

Simply hold it in place on the joist or stud and it attaches in seconds. The 90° back-stop ensures a level mounting position. Ducting fits over the top collar and the rigidity of the bottom circular opening ensures the diffusers and grilles stay snug against the finished surface.

PRODUCT DIMENSIONS

Sizes: 4", 5" and 6"

FEATURES & BENEFITS

- Quick and easy installation with no sharp edges.
- Can be used for ceiling or wall terminations.
- Preset for 1/2 and 5/8-inch drywall.
- 90° back-stop for a level, uniform installation with bottom flange for a permanent air seal.
- Off-set from joist for easy installation of ducting and clearance for application of tape or sealer.
- Duct-Stop-Point ensures no screws penetrate the collar and impede the insertion of the grille.
- A rigid bottom flange guarantees the drywall router tool conforms to the circular opening.
- V-shaped indentations on bottom edge for centering with previously installed fixtures.



Mounts on wood or metal.



Finished installation with Primex WG Series Diffuser

DC SERIES

PART #	SIZE	DESCRIPTION	PKG
DC4	4"	Terminator 4", black	25/box
DC5	5"	Terminator 5", black	25/box
DC6	6"	Terminator 6", black	25/box

Fast, Accurate Termination Every Time



Visit www.primexfits.com to view the Terminator installation video

PRODUCT MODEL CODE

EB4X90

90° Squeeze Elbow

HVAC VENTING Diffusers

The Primex 90° Squeeze Elbow (EB4x90) offers a venting solution for tight 2x4 wall and ceiling spaces.

Designed to work with the Primex WG4, WG4S and RDV4 air diffuser products, this unit offers a fast rough-in for quick and easy installation.

FEATURES & BENEFITS

- Impact-resistant, durable polymer resin 4" x 90° plastic stack hood elbow.
- Compatible with most 4" diameter Primex vents.
- Designed to fit 4" round duct inside 2x4 walls where space is restricted.
- Works well with WG4, WG4S, RDV4 and DC4.
- Fast rough-in and quick and easy installation.

COLOURS

- Black (25)

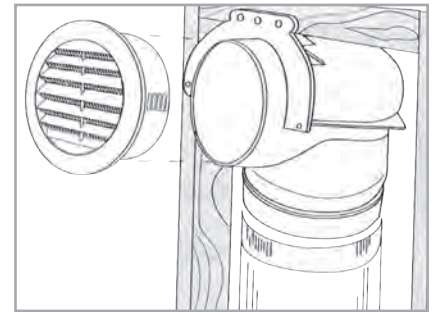

4" Round Vent installed with Primex's 'Squeeze Elbow' EB4x90

EB4X90

PART #	SIZE	DESCRIPTION	PKG
EB4x90	4"	90° Squeeze elbow	25/bag; 100/box (Bulk bin/875)

No other HVAC Venting company knows more about the relationship between the building envelope and HVAC systems.

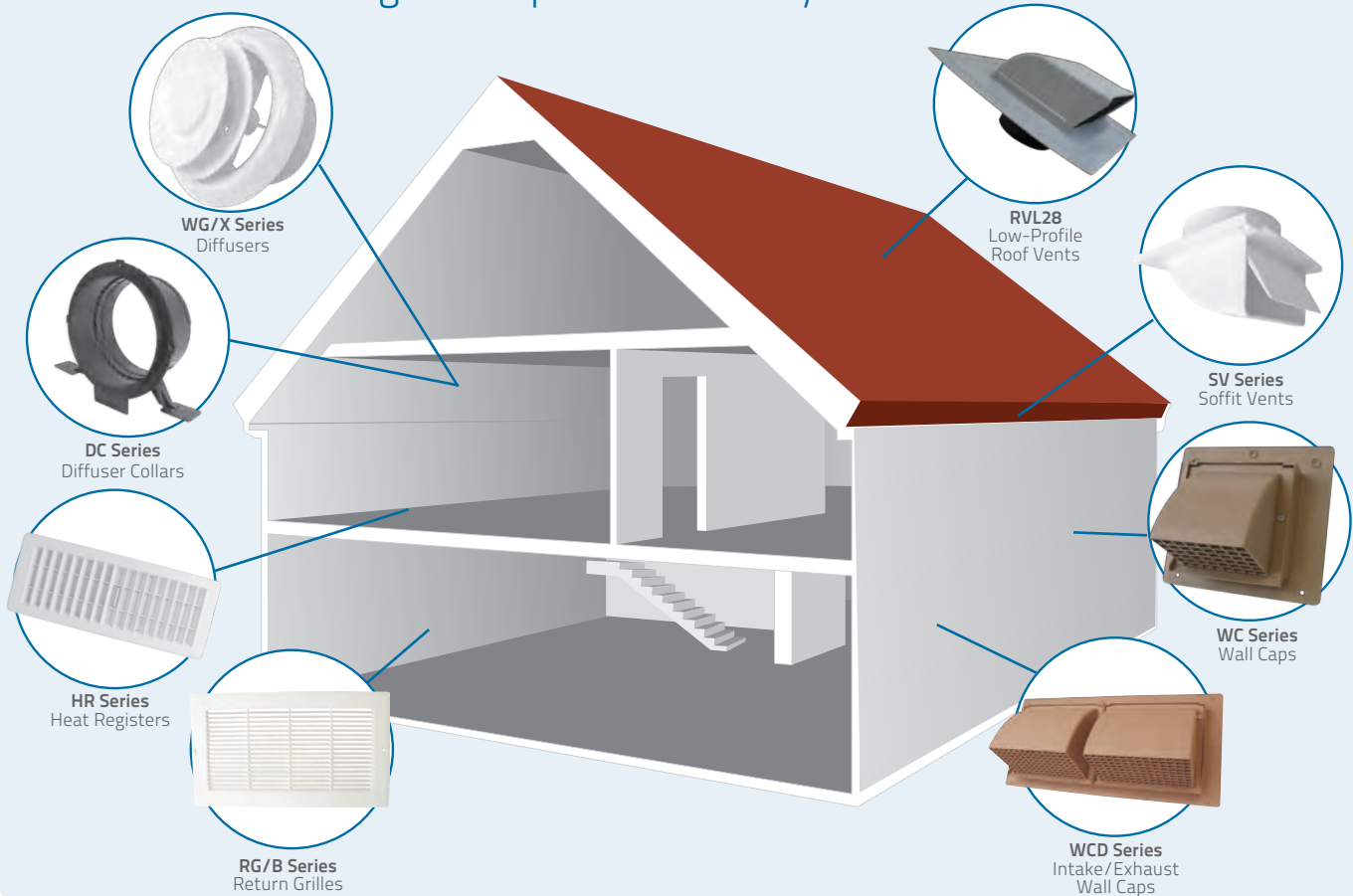

HVAC VENTING Registers

PRODUCT MODEL CODE

HR Series

Classic & Designer Heat Registers

The Primex Heat Register Classic and Designer Series (HR) offers a range of sizes and colours to suit every heat register application for the home.

Constructed of durable polymer resin, these registers come in nine different sizes and colours for floor, ceiling or sidewall installation. 'Finger tip' air control allows the user to easily adjust the amount of air flow.

Choose between the straight Classic Series or curved Designer Series.

FEATURES & BENEFITS

- Great for floor, ceiling, or wall applications.
- "Finger tip" air control.
- Nine sizes HR; two sizes HRA.
- Pins for end-user to affix filter cloth.
- Ten colours to choose from.
- Easy to clean.
- Made from high-strength, durable polymer resin.

COLOURS

STANDARD

- Snow White (01)
- Almond (03)
- Tan (04)
- Grey (05)
- Black (11)
- Taupe (23)

PREMIUM

- Chocolate Brown (06)
- Caramel (19)
- Woodgrain (20)
- Dark Brown (68)



Classic Series



Designer Series

(Only available in 3x10" and 4x10")

CLASSIC SERIES HEAT REGISTERS

PART #	COLLAR SIZE	FREE AREA	DESCRIPTION	PKG
HR210	2.25" x 10"	8 sq. in.	Floor / Ceiling / Sidewall	30/box
HR212	2.25" x 12"	9.6 sq. in.	Floor / Ceiling / Sidewall	25/box
HR214	2.25" x 14"	10.9 sq. in.	Floor / Ceiling / Sidewall	25/box
HR310	3" x 10"	9.5 sq. in.	Floor / Ceiling / Sidewall	25/box
HR408	4" x 8"	11 sq. in.	Floor / Ceiling / Sidewall	20/box
HR410	4" x 10"	13.8 sq. in.	Floor / Ceiling / Sidewall	20/box
HR412	4" x 12"	16.9 sq. in.	Floor / Ceiling / Sidewall	25/box
HR414	4" x 14"	19.6 sq. in.	Floor / Ceiling / Sidewall	15/box
HR612	6" x 12"	25.5 sq. in.	Ceiling / Sidewall	24/box

DESIGNER SERIES HEAT REGISTERS

PART #	COLLAR SIZE	FREE AREA	DESCRIPTION	PKG
HRA310	3" x 10"	9.4 sq. in.	Floor / Ceiling / Sidewall	25/box
HRA410	4" x 10"	14.2 sq. in.	Floor / Ceiling / Sidewall	20/box

Trim Plates

Protect exposed access points from leaks and moisture

Primex trim plates provide a range of watertight solutions for electrical, plumbing, and custom applications. One-piece molded designs with built-in drip edges ensure maximum protection against dangerous or corrosive water leaks.



MULTI-PURPOSE

- Get the right trim plate for the job with specialized options for electrical outlets, cable installs, dryer venting, doorbells, hose bibs, and exterior light fixtures.

LONGER LASTING

- Molded from specially formulated high-strength and UV-resistant polymer resin to ensure enhanced durability against sun, hail, and day-to-day wear.

PRODUCT MODEL CODE

201 Series
Standard Trim Plates

BUILDING PRODUCTS
Trim Plates

The Primex Trim Plate Series (201) is a collection of finishing plates for electrical, plumbing, and custom applications.

The Series consists of five different models configured for pre- or post-fitting installation.

Use the 201R and 201W together for retrofit applications where the fixture is already installed.

FEATURES & BENEFITS

- Excellent for door bells, HVAC Pipes, electrical outlets, water pipes.
- Eliminates leaky joints and maximises water protection with two-piece mold.
- The integrity of the building envelope is maintained with a seamless mold.
- Long lasting durability with UV-protected, impact-resistant, polymer resin.
- Reduces chance of injury with no sharp corners or metal edges that can cut or scrape.

COLOURS

Snow White (01)



201R
Electrical outlets and other fittings



201T
Tap, pipe or cable installations



201R + 201W
Combined for after tap installation



201W Adapter
Adapter for Primex's 201R & 301R trim plates



201S
Electrical fittings, dryer vents

201 SERIES			
PART #	SIZE	DESCRIPTION	PKG
201R	4.2" x 5.9" x 0.9"	Electrical trim plate	50/box
201T	4.2" x 5.9" x 0.9"	Hose bib	50/box
201S	6.4" x 6.4" x 0.9"	Electrical/dryer	50/box
201W	4.2" x 6.9" x 1.7"	Adapter for 201R/301R	50/box

BUILDING PRODUCTS

Trim Plates

PRODUCT
MODEL CODE

301/401 Series

Single Drip Edge Trim Plates

The Primex Trim Plate Series (301/401) is a collection of bottom drip-edge finishing plates for electrical, plumbing, and custom applications.

The Series consists of five different models made of durable, impact-resistant polymer resin.

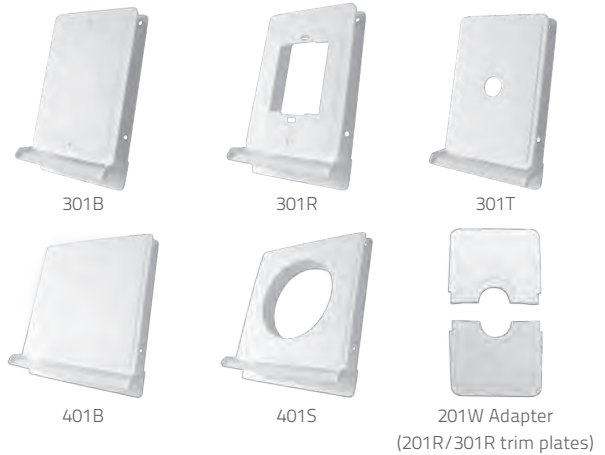

FEATURES & BENEFITS

- Excellent for door bells, HVAC pipes, electrical outlets, and water pipes.
- Eliminates leaky joints and maximizes water protection with two-piece mold, drip edge.
- Long lasting durability with UV-protected, impact-resistant polymer resin.
- Reduces chance of injury with no sharp corners or metal edges that can cut or scrape.
- 301R can use 201W for retrofit applications.

COLOURS

- Snow White (01)

301/401 SERIES

PART #	SIZE	DESCRIPTION	PKG
301B	4.2" x 6.9" x 1.7"	Outdoor bells/unfinished outlets	50/box
301R	4.2" x 6.9" x 1.7"	Electrical/other	50/box
301T	4.2" x 6.9" x 1.7"	Outdoor hose bib	50/box
401B	6.6" x 6.9" x 1.7"	Outdoor fixtures/unfinished outlets	50/box
401S	6.6" x 7.2" x 1.7"	Outdoor light fixtures/dryer vents	50/box
201W	4.2" x 6.9" x 1.7"	Adapter for 201R/301R	50/box

BUILDING PRODUCTS

Trim Plates

PRODUCT MODEL CODE

501 Series

Double Drip Edge Trim Plates

The Primex Trim Plate Series (501) is a trio of rainscreen-compatible, double drip-edge finishing plates for electrical, plumbing, and custom applications.

It meets the stringent requirements of the Alberta Building code that pertains to the 'trimming out' of building envelope penetrations.

The Series consists of the 501B (blank, custom fit), 501R (rectangular cut, electrical), and 501T (round, plumbing).

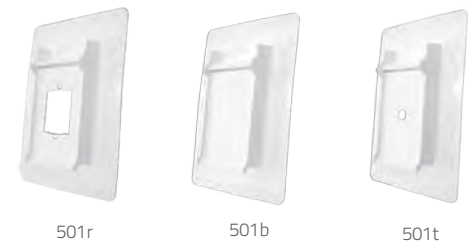

FEATURES & BENEFITS

- Excellent for door bells, HVAC Pipes, electrical outlets, and water pipes.
- Eliminates leaky joints and maximises water protection with one-piece mold and top and bottom drip edges.
- The integrity of the building envelope is maintained with a seamless mold and oversized flange.
- Long lasting durability with UV-protected, impact-resistant, polymer resin.
- Reduces chance of injury with no sharp corners or metal edges that can cut or scrape.
- 501R can use 201W for retrofit applications or faucet or line sets.
- Meets code and saves time without having to form drip edge in the field.

COLOURS

- Snow White (01)

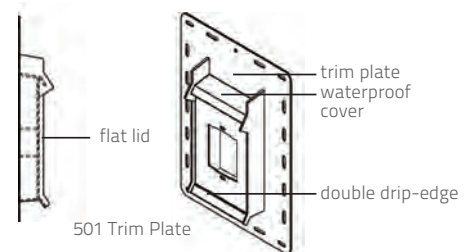

501 SERIES

PART #	SIZE	DESCRIPTION	PKG
501B	8.5" x 12" x 1.25"	Outdoor bells/unfinished outlet	20/box
501R	8.5" x 12" x 1.25"	Electrical/other	20/box
501T	8.5" x 12" x 1.25"	Outdoor hose bib	20/box

Gutter Accessories

Beat blockage and eliminate corner leaks

Gutters don't get enough credit. They're critical components in keeping a building safe from costly water damage and they take a relentless beating from the elements. Primex gutter accessories help keep vulnerable gutter joints watertight and narrow downpipes free from blockage while remaining durable and easy to maintain.

CLEAN FINISHING

Simple designs and clean one-piece molded designs blend seamlessly into the rest of your gutter system.

EASY TO MAINTAIN

Mitre corners snap in and out with ease and drop-in leaf strainers can be installed at ground level for easy cleaning.

UV-PROTECTED

- Primex gutter accessories are made with specially formulated UV-protected plastics that ensure long-lasting durability.

WIDELY COMPATIBLE

- Drop-in and ground-level leaf strainers are compatible with all sizes and shapes of standard downpipes and weeping tile.

PRODUCT
MODEL CODE

MI/MO Series

Gutter Mitre Corners

BUILDING PRODUCTS

Gutter Accessories

The Primex gutter mitre corners (MI/MO Series) allow for secure, interlocking connections between gutter sections.

Made from UV-protected durable polymer resin, the mitre corners are available in 4 or 5-inch and two colours (Snow White or Dark Brown).

FEATURES & BENEFITS

- Interlocking inside and outside strip styles available for strong, aesthetically pleasing joining.
- Available in two styles: inside and outside.
- Made with UV-protected durable polymer resin.
- The choice of industry professionals for years.
- Comes in standard 4" or 5" sizes.
- Bulk packaging of 25/box.

COLOURS

- Snow White (01)
- Dark Brown (68)

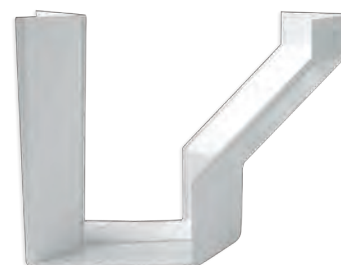

1 piece strip mitre for 4" fascia gutter



Outside strip

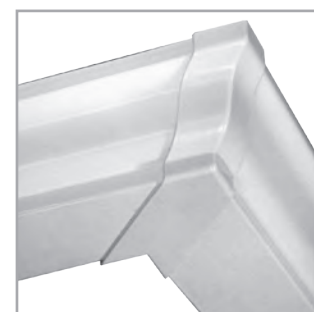
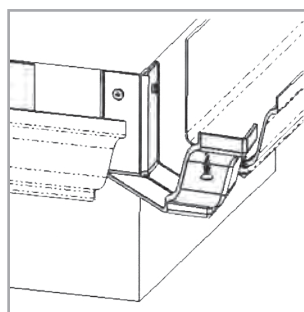

Interlocking inside

MI/MO SERIES			
PART #	SIZE	DESCRIPTION	PKG
MII4	4"	Mitre inside interlocking	25/box
MIS4	4"	Inside strip mitre	25/box
MII5	5"	Mitre inside interlocking	25/box
MIS5	5"	Inside strip mitre	25/box
MOI4	4"	Mitre Outside interlocking	25/box
MOS4	4"	Outside strip mitre	25/box
MOI5	5"	Mitre Outside interlocking	25/box
MOS5	5"	Outside strip mitre	25/box

BUILDING PRODUCTS

Gutter Accessories

PRODUCT MODEL CODE

LS401

Leaf Strainer Outlet

The Primex Leaf Strainer Outlet (LS401) is a durable filter that prevents debris from clogging weeping tile.

Made from UV-protected durable polymer resin, the LS401 fits easily and securely on standard 4-inch weeping tile.

It can be used as either a standalone filter or to supplement in-gutter strainers for extra protection.



DIMENSIONS

Size: 4" Diameter

FEATURES & BENEFITS

- Helps keep debris from clogging weeping tile.
- Mounts at ground level for easy cleaning.
- Can be used with all shapes and sizes of downpipe up to 4-inches.
- Made with UV-protected durable polymer resin.
- 4" outlet to fit 4" weeping tile.
- Bulk packaging of 25/box.
- Easy to clean.

COLOURS

- Snow White (01)

SV156			
PART #	FREE AREA	DESCRIPTION	PKG
LS401	4"	4x4 leaf strainer	25/box

BUILDING PRODUCTS

Gutter Accessories

PRODUCT MODEL CODE

OL Series

Leaf Strainer Outlets

The Primex Leaf Strainer Outlets (OL Series) are durable, easy-to-install filters that prevent debris from clogging gutter downspouts and drains.

Made from UV-protected durable polymer resin, there are three colours and three different sizes that fit a range of standard gutter openings.

FEATURES & BENEFITS

- Helps keep debris from clogging down spouts.
- Snap-in feature allows for easy installation.
- Made with UV-protected durable polymer resin.
- The choice of industry professionals for years.
- Pairs well with TC Series of tile covers.
- Available in three colours and three sizes.

COLOURS

- Snow White (01)
- Black (25)
- Dark Brown (68)



OLO25

OL2x3

OLO2

OL SERIES			
PART #	SIZE	DESCRIPTION	PKG (50/BAG)
OL2x3	2" x 3"	Rectangle outlet	300/box
OLO25	2.5"	Round outlet	200/box
OLO2	2"	Round outlet	500/box

PRODUCT MODEL CODE

TC Series

Down Spout Tile Covers

BUILDING PRODUCTS

Gutter Accessories

The Primex down spout tile cover series (TC Series) is a durable adapter that connects downspouts to drain tiles.

Made from UV-protected durable polymer resin, there are three colours and seven different sizes to choose from. Ensure a professional looking installation with the TC Series.

FEATURES & BENEFITS

- Tile adapters connect the downspouts to drain tiles.
- Streamlined design allows for quick and easy installation.
- Made from UV-protected durable polymer resin.
- The choice of industry professionals for years.
- Pairs well with the OL Series of tile covers.
- Available in three colours and seven sizes.

COLOURS

- Snow White (01)
- Black (25)
- Dark Brown (68)

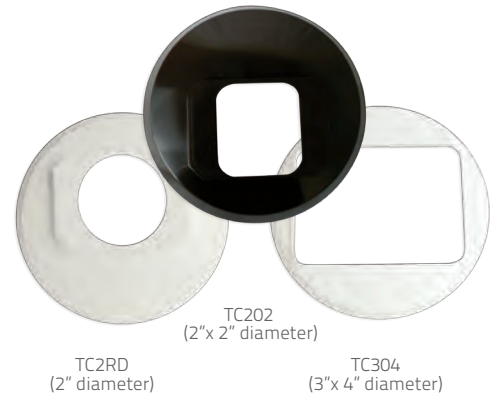

TC SERIES			
PART #	SIZE	DESCRIPTION	PKG
TC2RD	2"	Round cover	50/bag
TC202	2" x 2"	Square cover	50/bag
TC203	2" x 3"	Rectangle cover	50/bag
TC2222	2.25" x 2.25"	Square cover	50/bag
TC2525	2.5" x 2.5"	Square cover	50/bag
TC2727	2.625" x 2.625"	Square cover	50/bag
TC304	3" x 4"	Rectangle cover	50/bag

PRODUCT MODEL CODE

AP6x9SW

Access Panel

BUILDING PRODUCTS

Accessories

The Primex access panel (AP6x9SW) is an aesthetically pleasing and easy-to-install cover and frame unit.

At 6 by 9 inches, the AP6x9SW provides excellent coverage and easy access to plumbing or electrical systems.

DIMENSIONS

Size: 6"W x 9"H

FEATURES & BENEFITS

- Reversible frame for versatile installation mounting options.
- 6" x 9" access opening.
- Low profile design for ample room to work in.
- Quick and easy installation.
- Includes 2 installation screws.
- Available in Snow White.
- Made with UV-protected durable polymer resin.
- Bulk packaging of 25/box, shrink-wrapped and UPC'd.

COLOURS

Snow White (01)

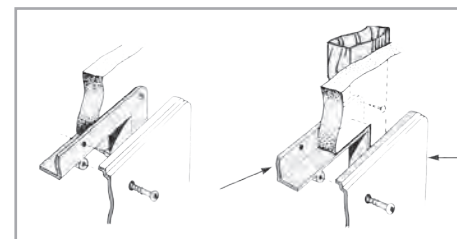

SV156			
PART #	SIZE	DESCRIPTION	PKG
AP6x9SW	6" x 9"	Access panel kit: includes cover and frame.	25/box

Product Colours and Codes

OUTDOOR PRODUCT COLOURS



01 - Snow White



23 - Taupe



25 - Black



28 - Dark Grey



31 - Light Grey



45 - Tan



68 - Dark Brown

INDOOR PRODUCT COLOURS

Premium Colours



06 - Chocolate Brown



19 - Caramel



20 - Wood Grain



68 - Dark Brown

Standard Colours



01 - Snow White



03 - Almond



04 - Tan



05 - Grey



11 - Black



23 - Taupe

Due to variations from printing and monitors, the colours that appear on this page may not reflect the accurate colour of Primex products. Custom colours are available.





About Primex

Established in 1971 and headquartered in Langley, British Columbia, Primex Manufacturing Ltd. (Primex) is a molder of plastic injection products.

From our roots as a small custom injection molder and through the combination of Primex's partner companies, Vanguard Plastics, Premo Plastics and VPL Enterprises Ltd., we have developed broad capabilities

in the design, engineering and mold fabrication of a number of proprietary, patented in-house plastic products.

We offer a full scope of products and services to meet the ever changing needs of both the HVAC and Construction industries.



Contact

Hours: 6am-4:30pm PST

Phone: 1.604.881.7875

Toll-Free: 1.778.881.7875

Fax: 1.604.881.7835

Email: info@primexfits.com

Web: www.primexfits.com

Connect



[facebook.com/PrimexVents](https://www.facebook.com/PrimexVents)



twitter.com/primexvents



LinkedIn: 'Primex HVAC Venting'



G+: 'Primex HVAC Venting'



YouTube: 'Primex HVAC Venting'

Subscribe

Blog

The latest in HVAC venting news! Informative and timely articles about all your favourite HVAC issues.

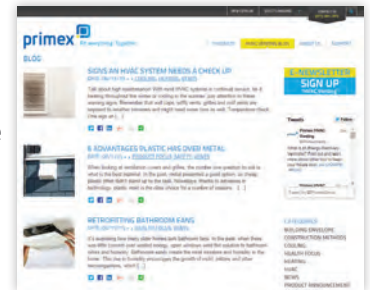

e-Newsletter

News, product announcements, features and more! The HVAC Venting monthly e-newsletter brings everything you need to know about HVAC right to your inbox. Subscribe online at: www.primexfits.com

PRIMEX MANUFACTURING LTD.

20160 92A Avenue, Langley BC V1M 3A4 Canada



© 2015 Primex Manufacturing Ltd. All rights reserved. No part of this publication may be reproduced by any means without written permission.

Primex Manufacturing Ltd. reserves the right to change design and specifications without notice. Printed in Canada. (08/15)